

SV-904

DATA CASSETTE USER'S MANUAL

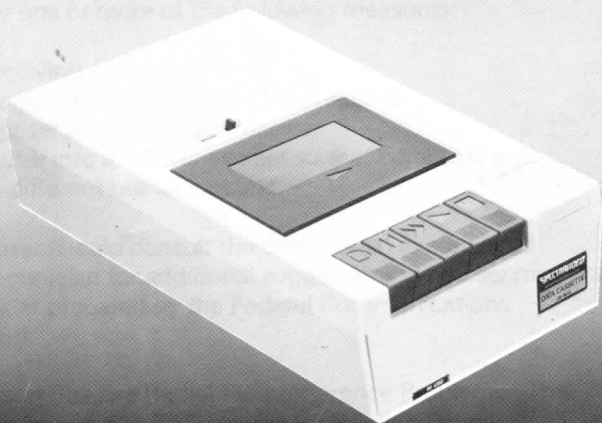

SPECTRAVIDEO™

SPECTRAVIDEO'S USER'S MANUAL STATEMENT

This equipment generates and uses radio frequency energy and if not installed and used properly, that is, in strict accordance with the manufacturer's instructions, may cause interference to radio and television reception. It has been type tested and found to comply with the limits for a Class B computing device in accordance with the specifications in Subpart J of Part 15 of FCC Rules, which are designed to provide reasonable protection against such interference in a residential installation. However, there is no guarantee that interference will not occur in a particular installation. If this equipment does cause interference to radio or television reception, which can be determined by turning equipment off and on, the user is encouraged to try to correct the interference by one or more of the following measures:

- Reorient the receiving antenna
- Relocate the computer with respect to the receiver
- Move the computer away from the receiver
- Plug the computer into a different outlet so that computer and receiver are on different branch circuits.

If necessary, the user should consult the dealer or an experienced radio/television technician for additional suggestions. The user may find the following booklet prepared by the Federal Communications Commission helpful:

"How to Identify and Resolve Radio-TV Interference Problems." This booklet is available from the U.S. Government Printing Office, Washington, DC 20402 Stock No. 004-000-00345-4.

WARNING:

This equipment has been certified to comply with the limits for a class B computing device, pursuant to Subpart J of Part 15 of FCC Rules. Only peripherals (computer input/output devices, terminals, printers, etc.) certified to comply with the Class B limits may be attached to this computer. Operation with non-certified peripherals is likely to result in interference to radio and TV reception.

DATA CASSETTE USER'S MANUAL

Congratulations. The Spectravideo data cassette recorder marks your entrance into Spectravideo's expanding universe of educational, entertainment and home management programs. This manual is your guide into this new and exciting world. In the coming chapters we will show you how to store and playback your BASIC programs in a few different ways. Please read this manual carefully and try every program that we provide as examples.

Published by
SPECTRAVIDEO INTERNATIONAL LTD.

First Edition
First Printing 1983
Printed in Hong Kong
Copyright © 1983 by Spectravideo International Ltd. All rights reserved

Every effort has been made to supply complete and accurate information in this manual. Spectravideo International Ltd. reserves the right to change Technical Specifications and Characteristics at any time without notice.

No part of this publication may be stored in a retrieval system, transmitted, or reproduced in any way, including but not limited to photocopy, photograph, magnetic or other record, without the prior agreement and written permission from Spectravideo International Ltd.

CONTENTS

PAGE

1. Features	5
2. How To Connect The Recorder To The SV-318	6
3. How To Save Programs Onto A Cassette Tape	7
4. How To Load A Program Into The SV-318	10
5. Some Other Ways To Save A Program On A Cassette Tape	12
6. Introduction To Data Files	14
7. Cautions And Maintenance	21
8. Specifications	23

ACCESSORIES

The package of the SV-904 should contain the following items:

- A) Cassette Drive with a 3-ft. cord (one end with connector)
- (B) This Instruction Manual

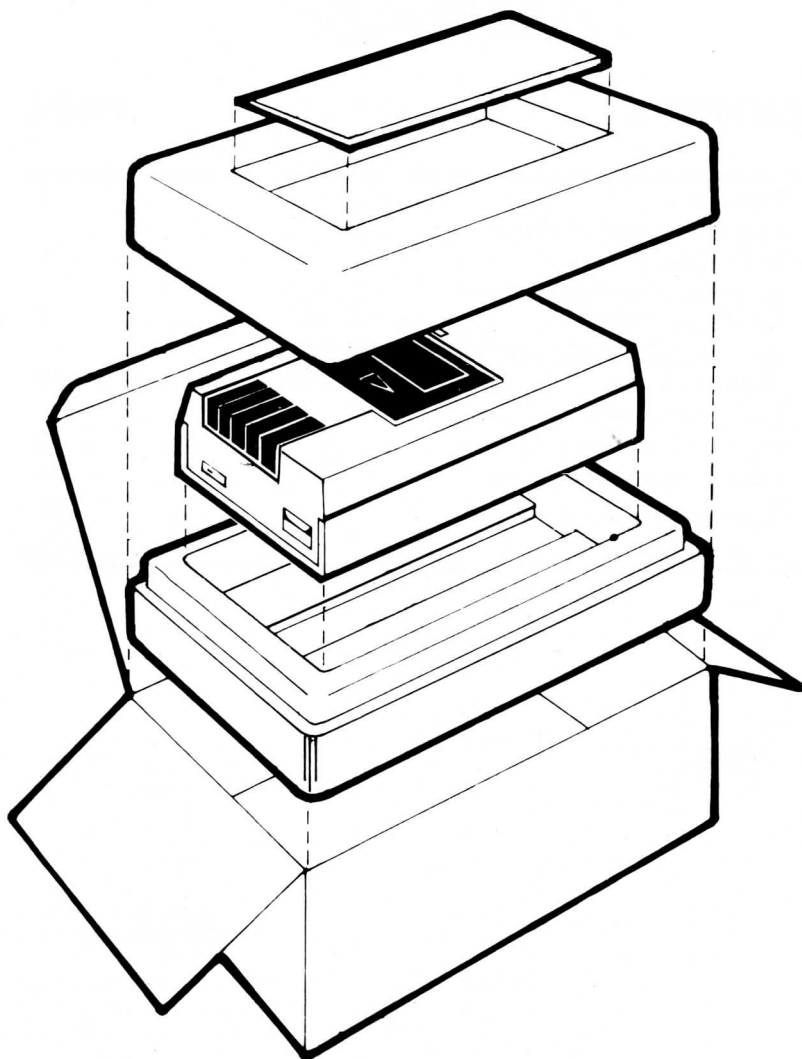

1.

Features

Main Features:

- A. Built-in tape counter for easy location of recorded program material.
- B. Battery-free — power supplied by SV-318 or SV-328.
- C. No interface needed — direct hook-up to SV-318 or SV-328.
- D. Automatic Stop Feature, which stops the recorder when the cassette reaches its end.

Other Features:

- A. LED indicator
- B. STOP/EJECT button
- C. PLAYBACK button
- D. FAST FORWARD button
- E. REWIND button
- F. RECORD button
- G. Cassette cover
- H. Counter reset button

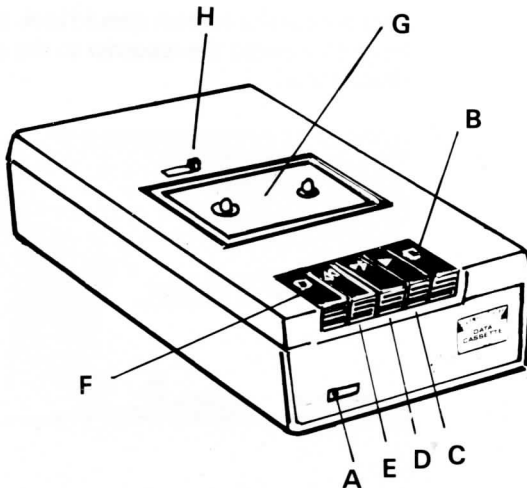

2.

How To Connect The Recorder To The SV-318

Insert the connector located on the tail end of the cable that is attached to the recorder into the slot on the back of the SV-318, as pictured below.



This is how the system should look after you have connected the recorder to the computer. (Back view)



3.

How To Save Programs Onto A Cassette Tape

1. Insert a cassette tape into the recorder. This procedure is the same as with most other cassette recorders. Press the **STOP/EJECT** button to open the cover. Insert the cassette with the tape opening facing towards the front of the recorder. If the tape is fully rewound, all the tape will be on the left-hand spool. Press down on the cover to close before continuing.

-
-
2. After you have written your BASIC program, insert the cassette tape into the recorder and make sure the recorder is connected to the SV-318. If you are using a new cassette tape, advance the tape past the leader to the section that is made for recording. You must be careful not to record on the leader. If you are using a tape that contains previously saved programs, then advance the tape past the last program that you wish to retain. If you record over a previously saved program, you will automatically erase that program.
 3. Type the command:

CSAVE

in immediate mode (the difference between immediate and program mode is explained at the beginning of the SV-318 User's Manual). After the word **CSAVE** you must then type the name you wish to give your program. For example, if you wrote a checkbook program you might type:

CSAVE "CHECKBOOK"

or,

CSAVE "CHBK"

or anything else you might want to call it. After you type **CSAVE** and the name of the program surrounded by quotation marks, press the **ENTER** key. The name you give it is the name with which it will be stored on the cassette and the name which you need to use to load it back into the computer (more on how to load later).

3. After you have pressed the **ENTER** key, the computer will respond by telling you to press the **PLAY** and **RECORD** keys on the recorder. Press these two keys and the computer will begin writing your program onto the cassette. Whenever the computer is recording onto the tape, the red "IN USE" light located on the bottom of the recorder will light up. When the computer has finished writing your program,

the red light will go off and the computer will print the "OK" message on the screen. That's it. Your program is now saved.

4. To interrupt the computer and stop it from saving a program, press the **CTRL** key and while holding it down press the **STOP** key. Then release the keys. The computer will print its "OK" message on the screen, and return control back to you.

Notes:

(G) Record Prevent Device

The cassettes used in this unit contain special "knockouts" to prevent accidental erasure of a program. These tabs (on the back of the cassette) can be replaced should you ever want to re-record on the tape.

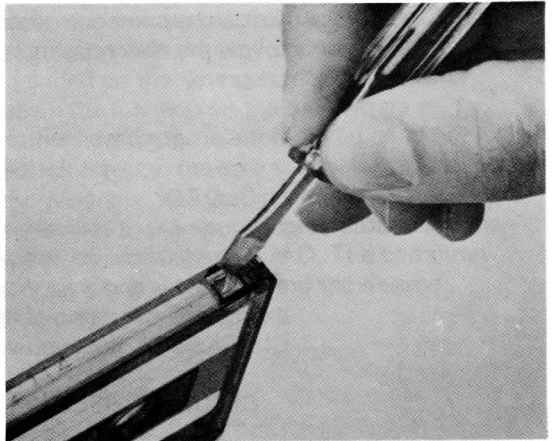

(J) Tape Counter

The tape counter is for easy location of material recorded on tapes. Push the reset button to set the tape counter to the "000" position. This is the position you start on for recording or playback.

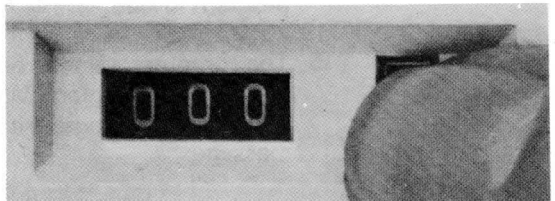

4.

How To Load A Program Into The SV-318

1. Insert the cassette tape that contains the program into the recorder.
2. Rewind the cassette tape fully by pressing the **REWIND** key on the recorder. All the tape should be on the lefthand spool.
3. If the program you wish to load is from a tape that you purchased (i.e. the program was written by someone other than you), then follow the directions included with the program.
4. If the program was written by you, then type

CLOAD

in immediate mode, followed by the name of the program and then press **ENTER**. For example, if the name of the program was CHECKBOOK then you would type

CLOAD "CHECKBOOK" (ENTER)

IMPORTANT: The computer considers the name "CHECKBOOK" to be different from the name "checkbook" or CHECKbook! Make sure that if you capitalized the name of a program when it was stored, that you capitalize it when you tell the machine which program to load.

5. The computer will then begin to search the tape for your program. When it finds the CHECKBOOK program it will print the message:

Found: CHECKBOOK

If other programs are stored on the tape before CHECKBOOK, the computer will print the message "Skip: DIARY" or whatever other programs are located on the tape prior to CHECKBOOK.

6. After the checkbook program is loaded into the SV-318, the computer will print its "OK" message on the screen. You can then RUN the program.

7. If the computer does not find the program you named in the CLOAD instruction in the amount of time that you thought it should, then perhaps your program is not on that tape. To stop the computer from LOADing, press the **CTRL** key and while holding it down press the **STOP** key. Then release the keys. The computer will print its "OK" message on the screen and return control back to you. This is the reason that the tape counter indicator is included on the data recorder. If you write down the location on the tape where a particular program is stored, you need not later search through the entire cassette tape to find the program. You would simply **FAST FORWARD** to the appropriate number and then tell the computer to CLOAD. The computer will almost immediately find the desired program.

5.

Some Other Ways To Save A Program On A Cassette Tape

In chapter 4 we explained how to save your program. Actually, the **CSAVE** command is only one of three different ways to save programs. Each of the three methods has its advantages and disadvantages. We will now explain the other two ways to save your work and the technique the computer uses to save your program. Knowing how the computer saves your programs is important in understanding the advantages and disadvantages in each method. We have already described the **CSAVE** command so we begin with an explanation of this method.

CSAVE

When you use the **CSAVE** command, the computer "tokenizes" your program. If the computer saved every BASIC command that you typed exactly as you type it, on a cassette tape, it would take much longer than it actually does. Each character would have to be written, and even though the computer can handle the characters and numbers quickly, it still would take more time than you would care to wait.

Therefore, when the **CSAVE** command is issued, the computer assigns one value for each BASIC command that you use. These values are called tokens, hence the process is called "tokenization." Storing one character instead of several is a big time saver because the program is saved and loaded very quickly.

BSAVE

The **BSAVE** and **BLOAD** commands allow specific portions of the RAM to be saved and loaded. These commands are suggested for the more advanced user. Further information

HOW TO SAVE PICTURES

can be found in the Spectravideo BASIC Reference Manual available from your Spectravideo dealer.

Wouldn't it be nice if there was a way to save the beautiful pictures that you can create on a screen, through use of the computer, onto a cassette tape? Well, there is! And it's really very simple:

Step 1. Write your graphics program that uses SCREEN 1 or SCREEN 2 (the two graphics screens) and then RUN your program.

Step 2. Press the **CTRL-STOP** key combination and then type:

```
csave "name", s
```

So, if you draw a circle you might type:

```
csave "circle", s
```

That's all there is to it. Later when you want to see your work of art type:

```
cload "circle"
```

6.

Introduction To Data Files

The CSAVE command saves only your program. Remember that a program is the collection of commands . . . your instructions to the computer. The work that the computer performs and outputs, such as a list of all the possessions in your home, or a list of all your friends that you can update cannot be saved using the CSAVE command. To store these types of lists and print them out whenever needed, you must create a data file. Before describing how to create a data file, though, we must understand what it is.

Before the computer age, anytime someone referred to a filing cabinet a picture of a unit of steel drawers loaded with papers probably came to mind. Well, even after the dawn of the computer era, the concept of a file hasn't changed much. A file is a collection of information, kept somewhere other than inside the computer's memory area, that stores programs. That "somewhere" can be a cartridge, a cassette tape or a floppy disk.

To keep order in a filing system—whether it is a conventional filing cabinet or a cassette tape—one must organize the files into distinct units. If one were to label all the files in a drawer with merely the name "bills," it would be difficult to distinguish between bills that have already been paid and those that are still outstanding. Similarly, if one were to name all the files he saved on a cassette tape in the same way, it would be difficult to distinguish between the files.

The type of data file that is created as a result of following the upcoming directions is called a

“sequential” file. As its name implies, the data is written sequentially, that is one item after the other, in the order it is sent to the cassette. It is loaded back into the computer in the same way.

The following steps must be included in a program to create and access a sequential file. The ease of working with data files will be greatly enhanced if you continually bear in mind the parallel between a computer data file and the folder file stored in a filing cabinet. The following 4 steps are common to both.

1. **OPEN** the file for output (from the computer to the cassette tape).
2. Write data to the file using the **PRINT #** command (or other commands).
3. **CLOSE** the file after you have written to it. To read data from a file you must **OPEN** it again for input (from the cassette tape into the computer).
4. Using **INPUT #** command (or others) to read the data.

The above mentioned commands, and several others that are used to create and access sequential commands, are illustrated and explained through the use of sample programs. Please type the programs carefully and try them out.

DEMO #1

The first demonstration program highlights the following four fundamental commands:

OPEN
CLOSE
PRINT #
INPUT #

PART I

```
10 open "demo1" for output as #1
20 a = 10: b = 20
30 c = 30
40 Print#1, a;b;c
50 close#1
```

After you type part one, RUN it. This program will save the numbers 10, 20, and 30 on the tape.

Line 10 instructs the computer to **OPEN** (create) a file on the cassette tape called demo 1 to which we will output, or write information. The #1 at the end of line 10 is the filenumber for the demo#1 file.

The filename is the label that you use to refer to the file. The filenumber is what the computer uses to refer to the file. The filenumber is a unique number that is associated with the physical file when it is OPENed. It identifies the route that the computer uses to send and receive information with the data cassette recorder. Very rarely will you need to access more than one file at a time. Therefore, use filenumber 1 for those instances when you are using only one data file. To specify the maximum number of files you will open at once, use the following Format:

maxfiles = [number of files]

Lines 20 and 30 define the variables the program will use.

Line 40 is the one that actually instructs the computer to write them on tape, and line 50 closes the demo# file (filenumber 1).

Now, we will write part two of this program to read and print the information that was written on the tape in part one.

PART II

```
10 open "demo1" for input as #1
20 input#1, a,b,c
30 print a,b,c,
40 close#1
```

After you type this part in, rewind the tape and RUN the program. After you press the play button on the recorder, the numbers should be read and printed. Here's why.

On line 10 the computer is instructed to reopen the file to be able to read the information back into the computer. Notice that the filename again is #1.

Line 20 causes the computer to read the information back into the computer, and line 30 prints out the specified variables. Line 40 closes the demo1 file.

DEMO #2

This program illustrates the **LINE INPUT#** command. The first part of this program writes the string variables a\$ and b\$ on the tape.

PART 1

```
10 open "demo2" for output as #1
20 a$ = "this is a demonstration"
30 b$ = "this is part of it too"
40 Print#1, a$,b$
50 close#1
```

After you have typed part one, RUN it. Then type part two.

PART II

Part two will read and print the text stored in a\$ and b\$ using the command, LINE INPUT#.

```
10 open "demo2" for input as #1
20 line input#1, a$
30 close#1
```

The new command, LINE INPUT# appears on line 20 of part two. This command reads an entire line (up to 254 characters), without delimiters, from a sequential file to a string variable.

DEMO #3

This program demonstrates the last major command needed for sequential data file creation and access. The command is **EOF**, which is the abbreviation for "End Of File." First type in part one.

PART I

```
10 open "demo3" for out put as #1
20 for a = 0 to 50
30 print#1, a
40 next a
50 close#1
```

RUN part one.

PART II

```
10 open "demo3" for input as #1
20 if eof (1) then goto 70
30 input#1,a
40 print a
50 goto 20
60 close#1
70 print "all done"
```

Rewind the tape and RUN part two.

This program writes the numbers 0-50 into a file and then reads them back and prints them on the screen. It prints the message "all done" when it finishes. What is so great about that you ask? Well, before we explain the function of EOF, delete line 20 from part two of the program, change line 50 to read "goto 30" and then RUN the program. Did you get this error message?

input past end in 30

You probably did because after the computer prints the last item in the file, number 50, it returns to the file looking for more data to read (because line 50 sent it to line 30 which tells it to read). But since there is no more data left in the file, you are told that you tried to input (transfer from tape to computer) past the end of the file.

So how does the EOF command help? The EOF function tests to see whether or not the end of a file is reached. If the end of a file has been reached (true), then the value that EOF returns (transmits) to the program is 1 (one). A 0 (zero) will be returned if the end of the file has not been reached. Now let's look at line 20 again. Here is how to read it:

If the end of the file has been reached, then goto 70.

Before each item is read, the EOF tests to see if the end of file has been reached. If it has not been reached (the false or zero condition), the program continues to line 30. However if the EOF test reports a true (1) condition then the program jumps to line 70 and prints the "all done" message, thus avoiding the "input past end" error message.

This brings to a close our discussion of sequential data files. Two minor commands that can be used when working with sequential data files have not been demonstrated. They are:

**PRINT# USING
INPUT\$**

These commands are described in the Spectravideo BASIC Reference Manual.

7.

Cautions And Maintenance

Cautions

- (A) Use this unit in the horizontal position only.
- (B) Do not operate this unit in an area where the temperature is high, or where there is direct sunlight.
- (C) Periodic cleaning of the head assembly is necessary to avoid dirt.
- (D) Be sure to press the stop button before removing or inserting a cassette tape.
- (E) Metal cassette tape is not recommended for this cassette deck. Tapes of less than sixty minutes will provide optimal performance with this unit. If more than sixty minutes playing time is required, be sure to select a high quality cassette tape capable of reliable performance.

Maintenance

- (A) The head assembly, the capstan and the pressure roller are always in contact with the tape during operation. Therefore, they tend to get dirty very easily and this has an adverse effect on the recording quality and the volume. Occasional cleaning is necessary.

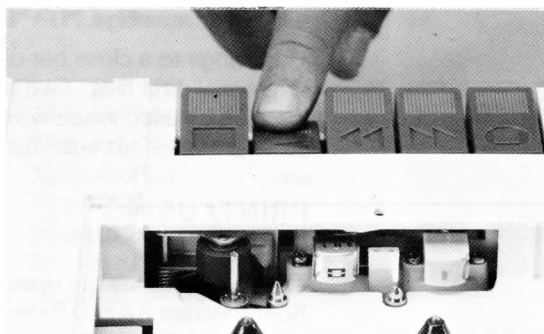

-
-
- (B) To clean the head assembly, remove the cassette and push the playback button. The head assembly then becomes accessible. Use a cotton swab dipped in denatured alcohol or head cleaning fluid.
- (C) Don't allow magnetic materials, such as a screwdriver or a magnet, near the head assembly.
- (D) When cleaning, be careful not to bend the tape guide.

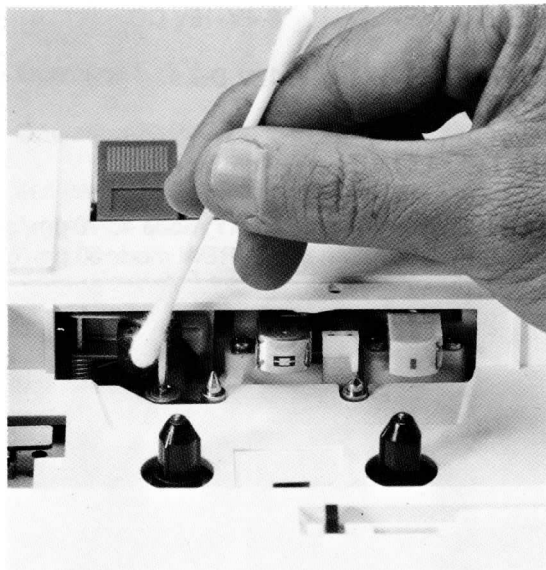
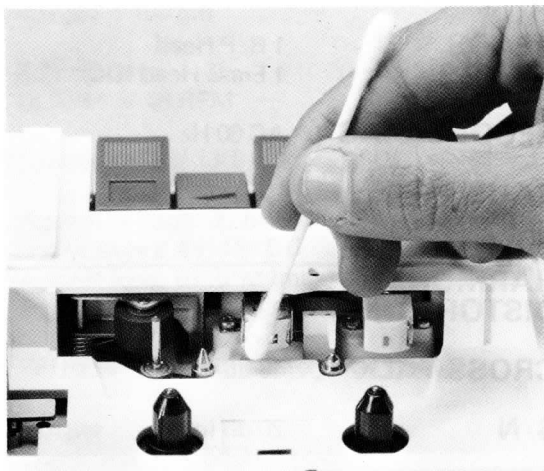

Specifications

These specifications are subject to change, in order to accommodate improvements in design.

FUNCTIONS	REC/REW/FF/PLAY/STOP/EJECT
HEADS	1 R/P Head 1 Erase Head (DC)
RECORD BIAS	AC 60 Hz
BAUD RATE	1,800 BPS
THIRD HARMONIC DISTORTION	3%
CROSS TALK	40 db (min)
S/N	20 db (min)
OPERATING VOLTAGE	8.4V-15V DC
RATED VOLTAGE	12V DC
RATED LOAD	9 gm/cm
TORQUE	PLAY mode 40-70 gm/cm FF/REW mode 60 gm/cm

**PINCH ROLLER
PRESSURE**

450 gm + 100 gm

TAPE SPEED

4.75 cm/sec. + 3%
24 RPM + 48 RPM

WOW & FLUTTER Less than 0.3% (JIS)

**FLUCTUATION
OF SPEED**

Against voltage: 30 RPM (max) at rated load
and voltage 8.4V -15V DC
Against load: 50 RPM (max) at rated voltage
ad load 8 gm/cm to 12 gm/cm

WINDING TIME

FF/REW 100 sec (max) for C-60 tapes

COUNTER

3 digits

**OTHER
FEATURE**

Power-ON LED indicator

TEMPERATURE

Operating 5-35°C

HUMIDITY

Operating 30-90%

**DIMENSIONS
(mm)**

164 (W) x 251 (D) x 68 (H)

WEIGHT

Approximately 1.08 KG

